

DONDOLO

Relax

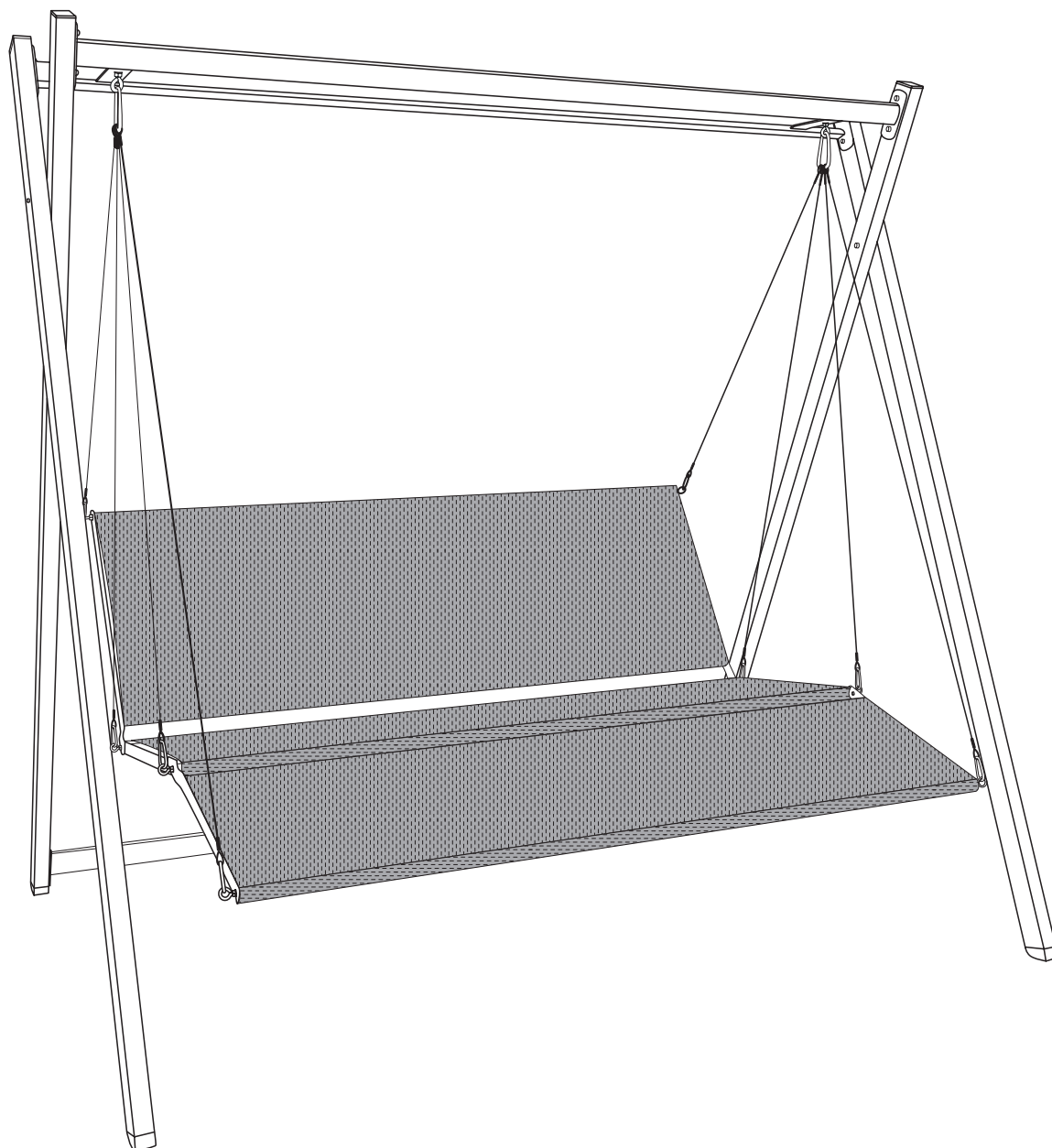

ISTRUZIONI PER IL MONTAGGIO

COMPONENTI SINGOLI

parte dello schienale con viti ad anello **1x**

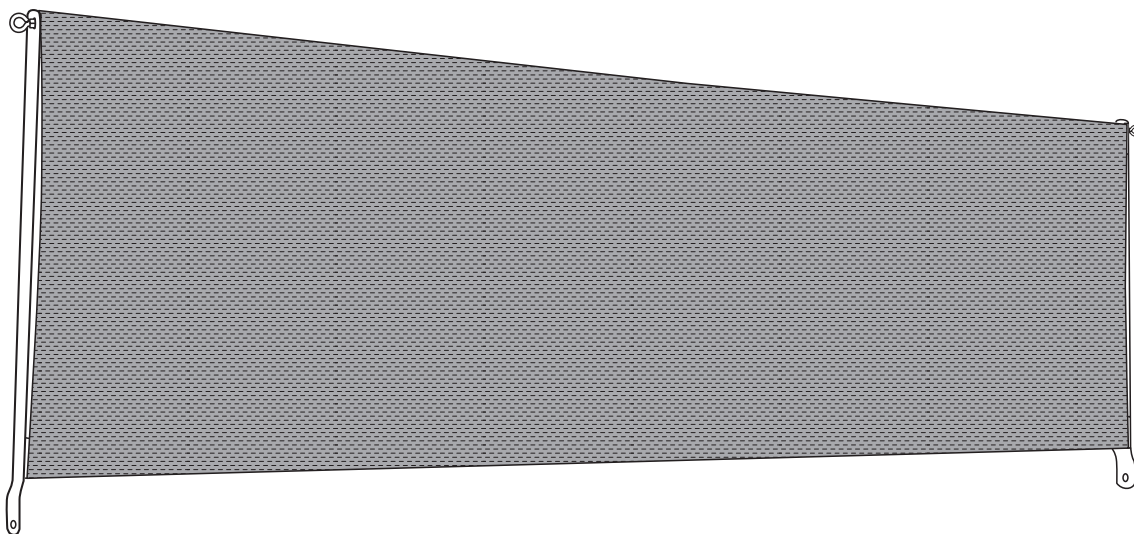

seduta **1x**

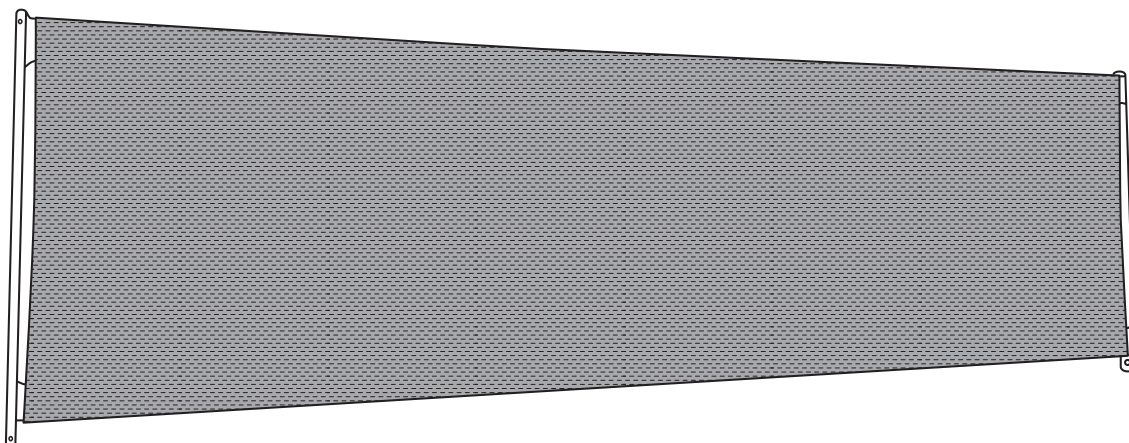

poggiapiedi con viti ad anello **1x**

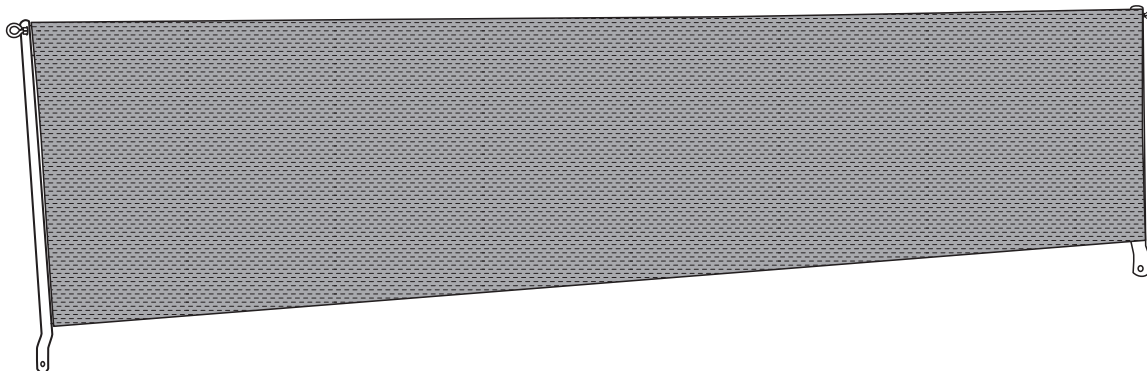

COMPONENTI SINGOLI

telaio colmo **1x**

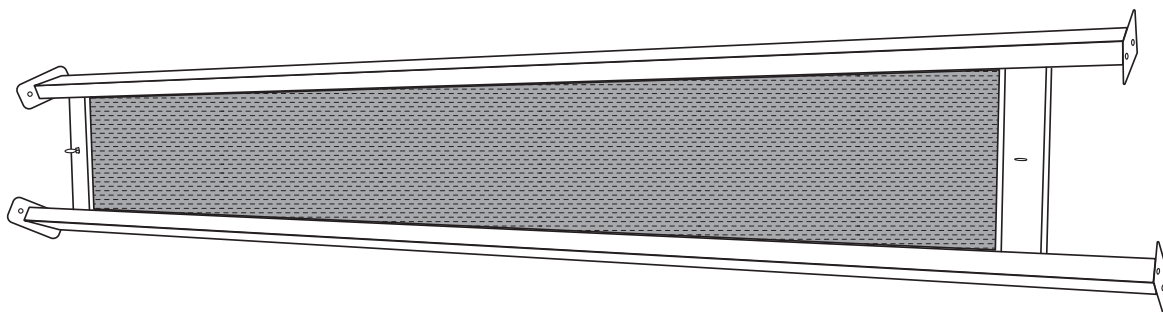

tubo trasversale **1x**

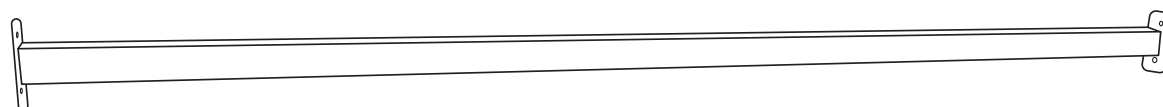

parte laterale destra **1x**

parte laterale sinistra **1x**

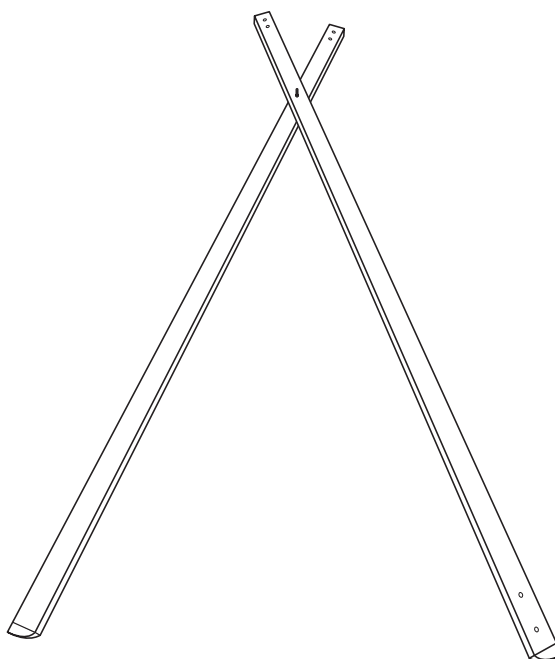
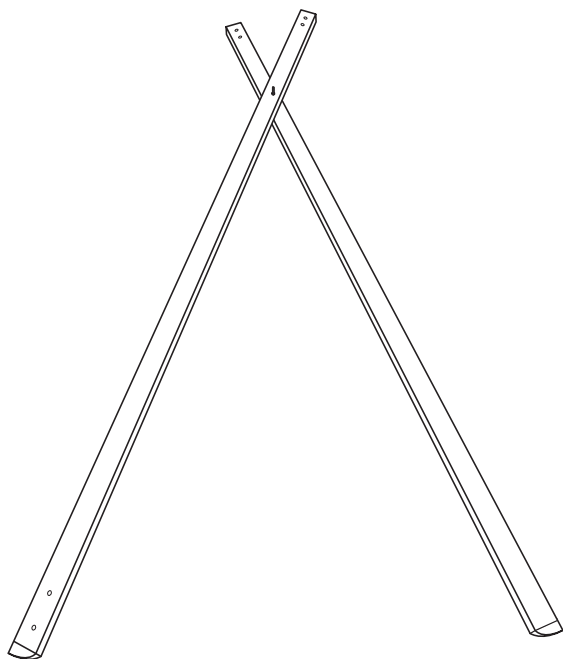

COMPONENTI SINGOLI

set funi con moschettoni **2x**

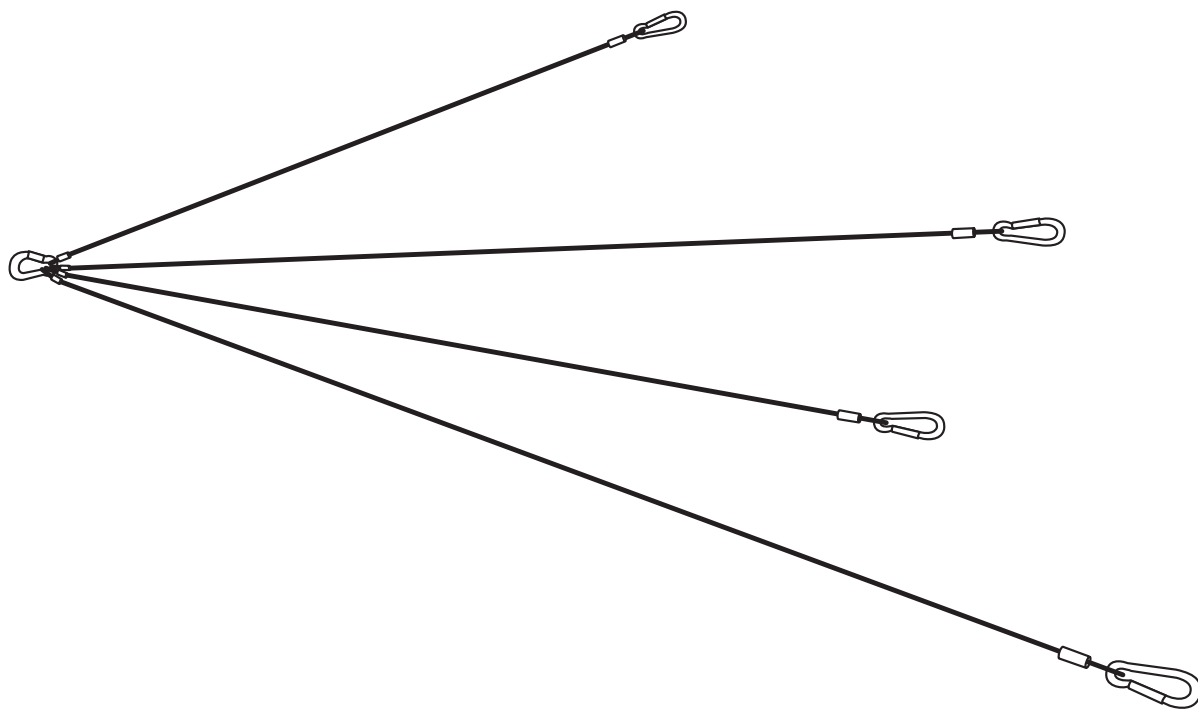

vite a brugola M6 x 16 **12x**



rondella 6 **12x**



rondella 8 **2x**



dado M8 **2x**



chiave a brugola **1x**

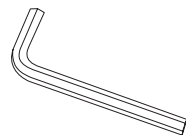

vite ad anello M8 **4x**



cappuccio con dado **2x**



MONTAGGIO

01

Collegare il telaio del colmo con le parti laterali

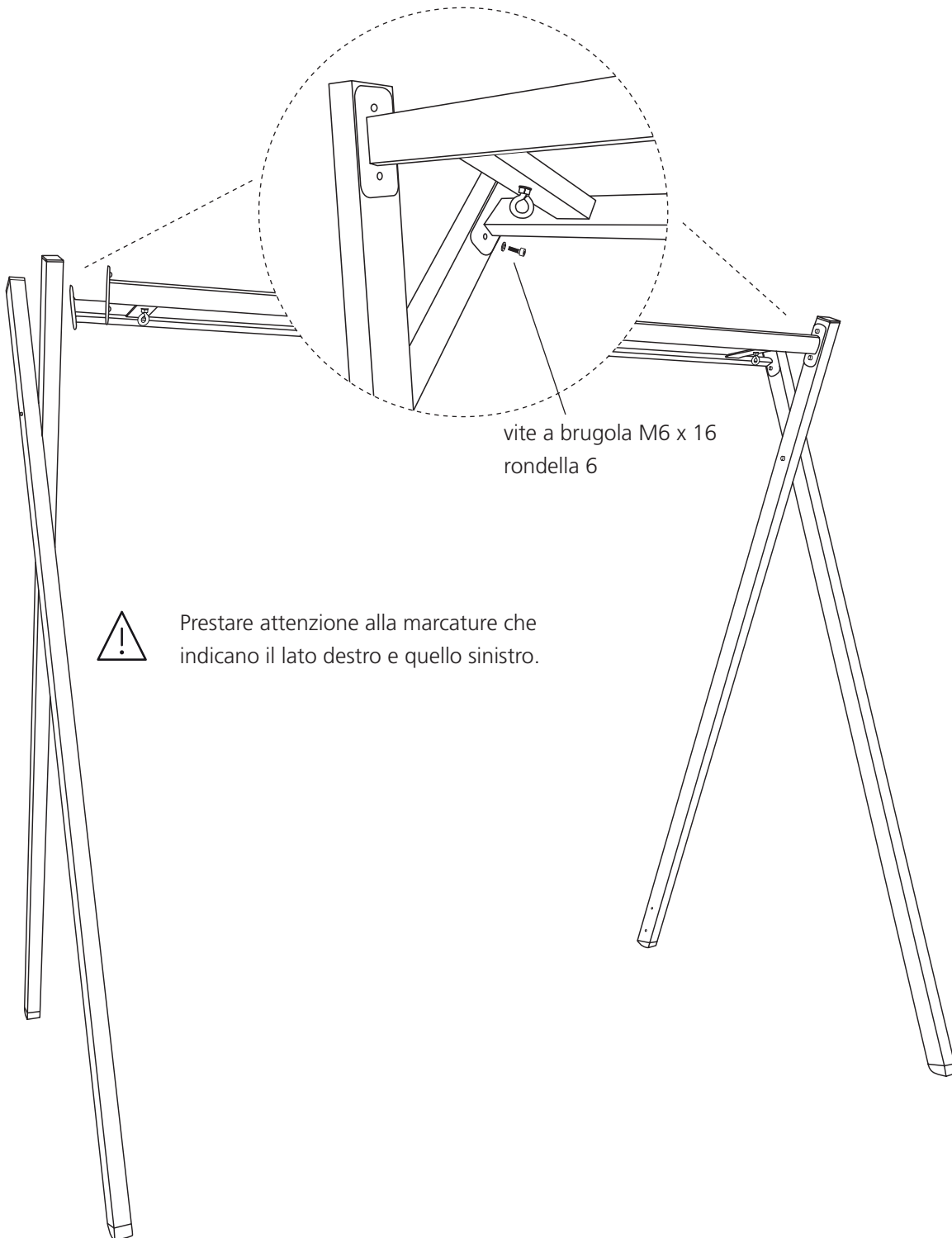

MONTAGGIO

02

Montare il tubo trasversale

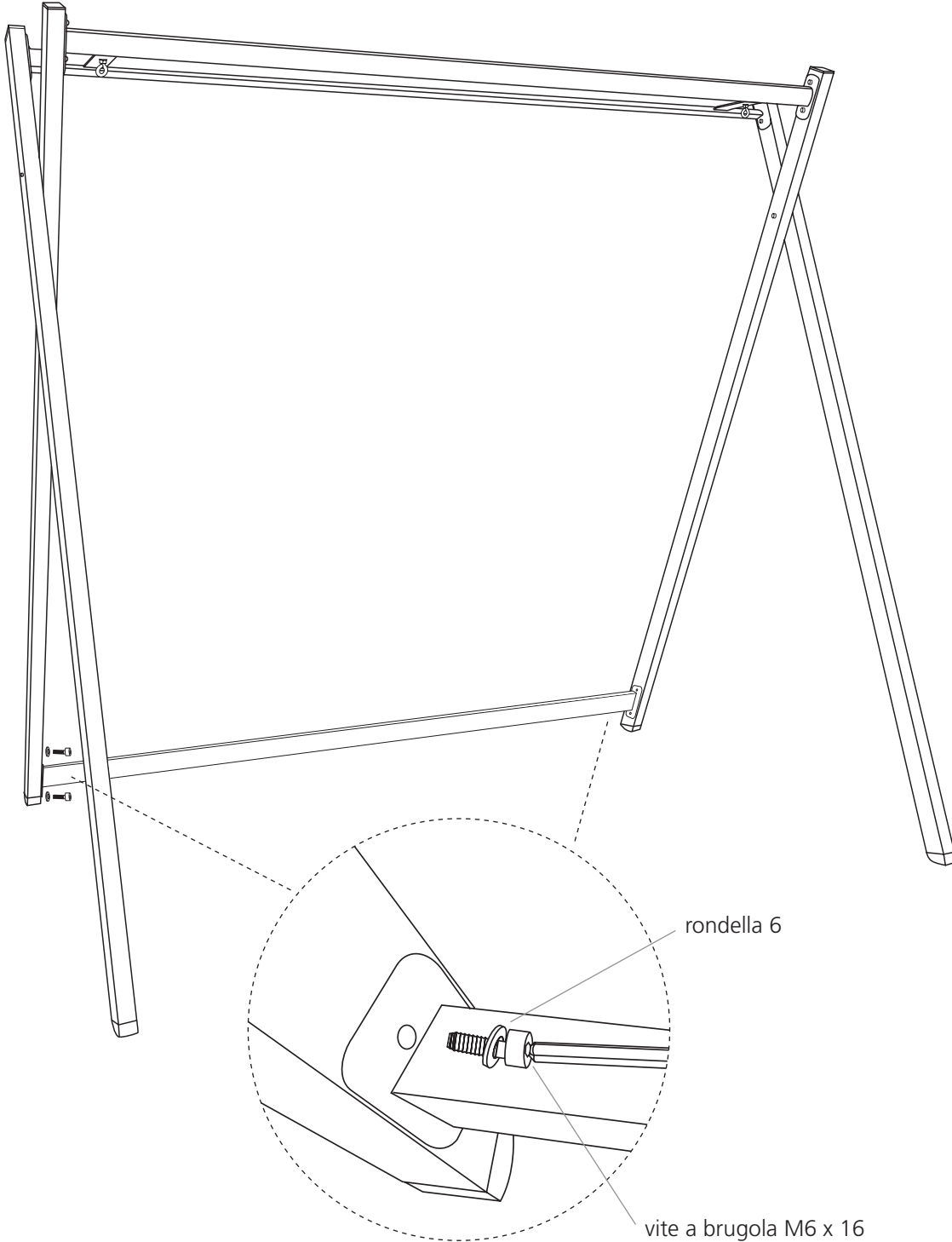

MONTAGGIO

03

Avvitare la seduta con lo schienale ed il poggiatesta

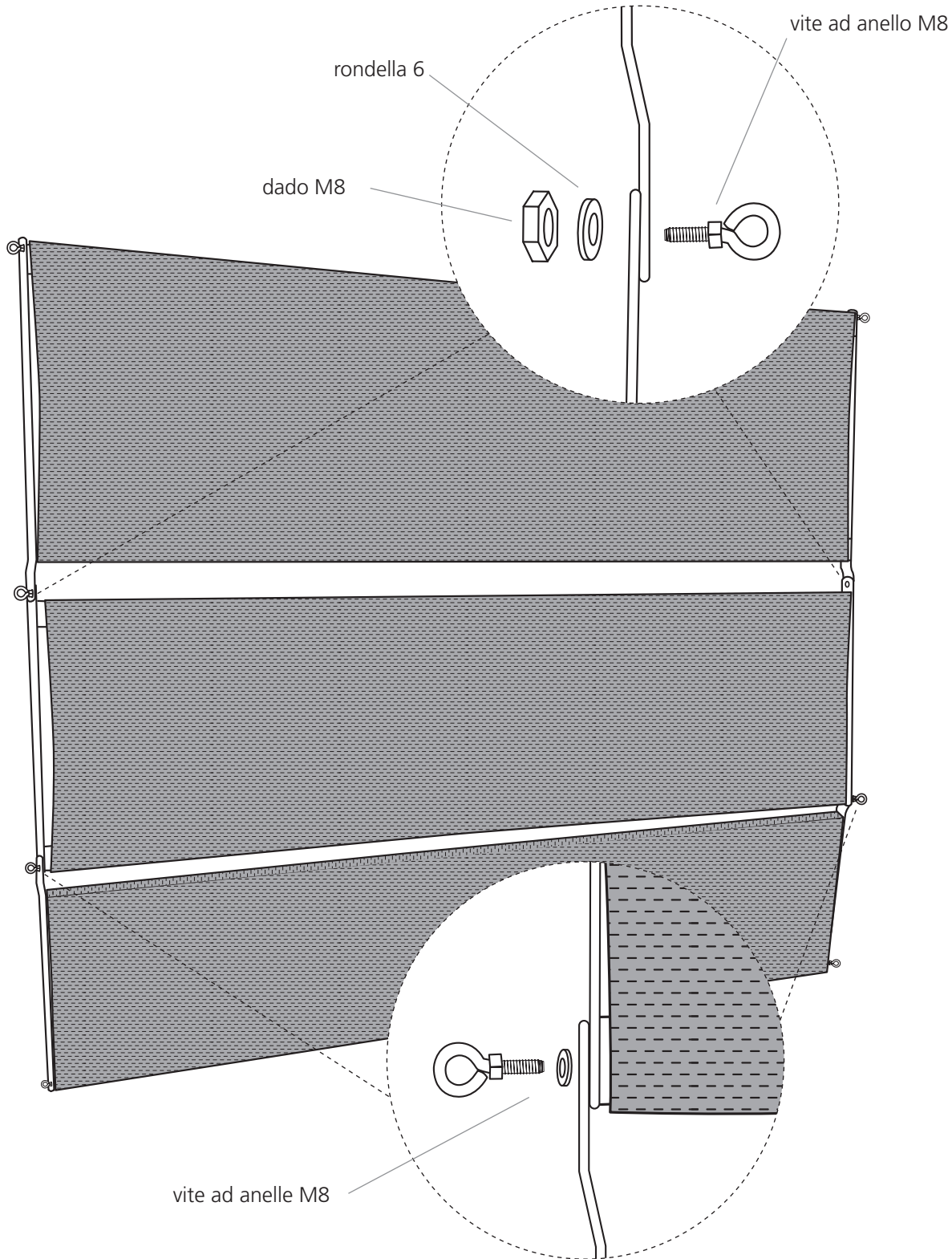

MONTAGGIO

04

Inserire le funi di metallo

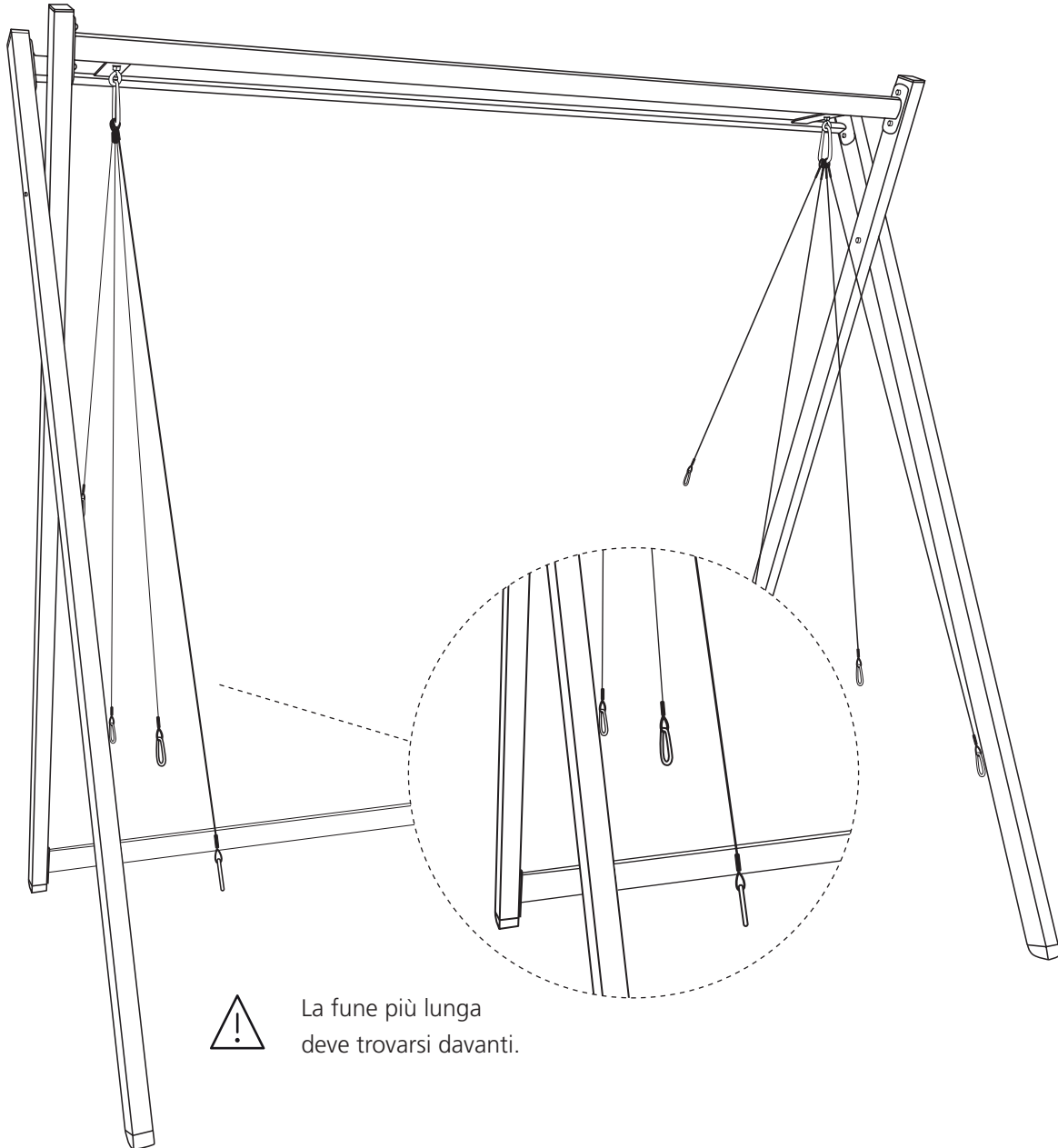

MONTAGGIO

05

Agganciare il telaio della seduta e dello schienale nei moschettoni

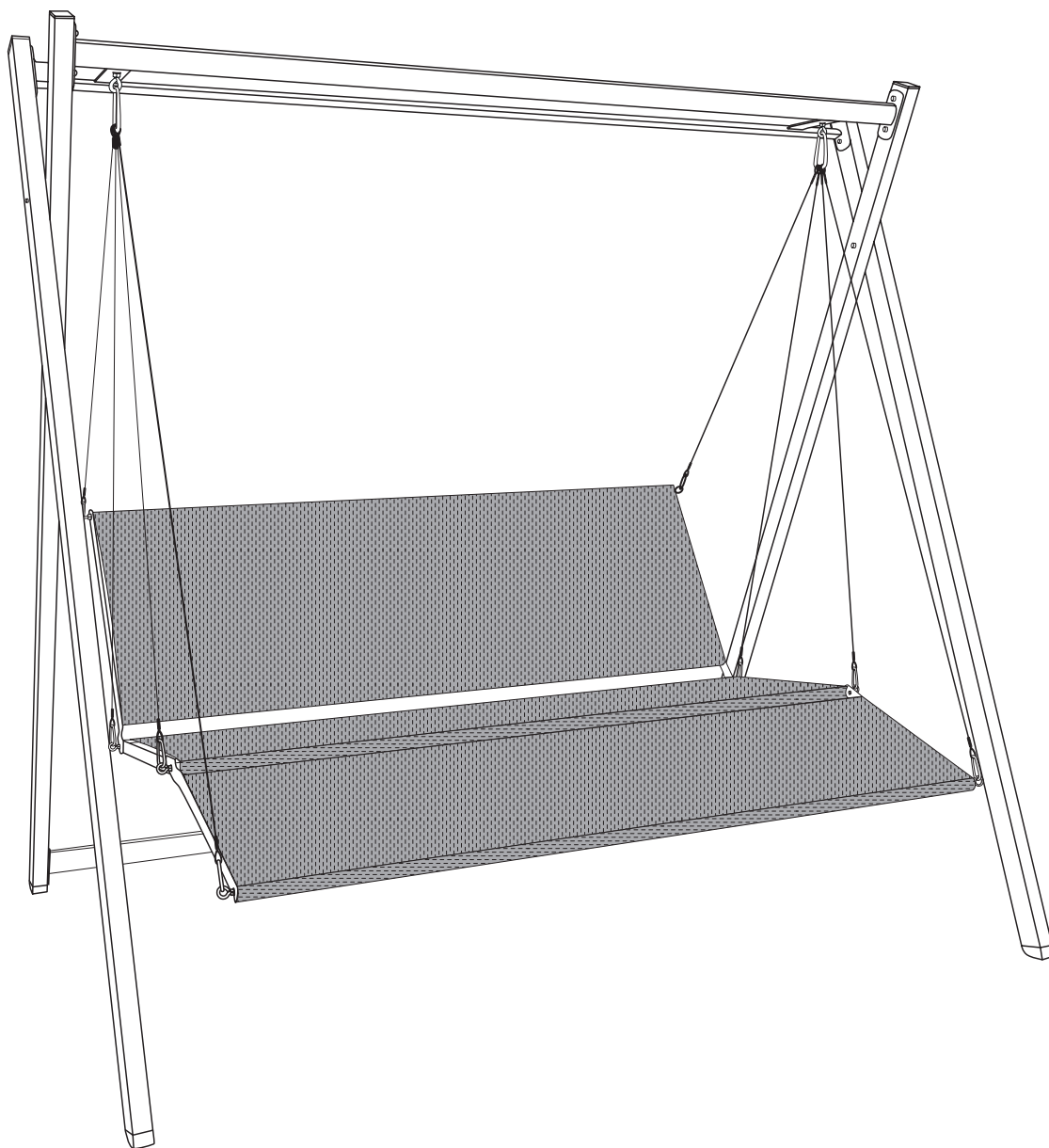

AVVERTENZE

Avvertenze importanti

- Portata:
 - 3-posti fino a 240 kg
- Onde evitare danni alla verniciatura della struttura effettuare occasionalmente una lucidatura con prodotti appositi, normalmente in commercio
- In caso di non utilizzo, togliere i cuscini

Accessori consigliati:

- Portabevande
- Penna smalto
- Cuscini per esterni, adatti al design del dondolo

Riservato tutti i diritti. La ristampa e la duplicazione in qualsiasi forma, anche soltanto parziale, sono consentite soltanto con l'autorizzazione scritta dell'autore.

Angerer Freizeitmöbel GmbH

84543 Winhöring · Postfach 1220 · Germania

Fax: +49 (0) 86 71 / 97 76 41

E-Mail: dondolo@angerer-freizeitmoebel.de

Web: www.Angerer-Freizeitmoebel.de/it

ISTRUZIONI PER IL MONTAGGIO

Angerer Freizeitmöbel GmbH

84543 Winhöring · Postfach 1220 · Germania

Fax: +49 (0) 86 71 / 97 76 41

E-Mail: dondolo@angerer-freizeitmoebel.de

Web: www.Angerer-Freizeitmoebel.de/it



Europäische Union

Europäischer Fonds für
regionale Entwicklung